

Montageanleitung

Differenz-Überströmventil DÜ

Lindenstraße 20
74363 Güglingen

Telefon +49 7135 102-0
Service +49 7135 102-211
Telefax +49 7135 102-147
info@afriso.com
www.afriso.com

Version: 05.2024.0
ID: 853.099.0150

Das Differenz-Überströmventil DÜ eignet sich ausschließlich zum Einbau in geschlossene Heizungsanlagen nach EN 12828. Es hält den Pumpendruck konstant und verhindert störende Fließgeräusche im Teillastbetrieb. Das Differenz-Überströmventil wird geöffnet, wenn der anstehende Pumpendruck den eingestellten Wert im Differenz-Überströmventil übersteigt.

- ▶ Das Differenz-Überströmventil in einer Bypassleitung zwischen Vor- und Rücklauf einbauen.

Parameter	Wert
Betriebstemperatur	Max. 95 °C (kurzzeitig bis max. 120 °C)
Betriebsdruck	Max. 6 bar
Differenzdruck	Stufenlos einstellbar
# 42379	0,1 – 0,5 bar
# 42384	0,1 – 0,5 bar
# 42308	1 – 5 m H ₂ O
# 42460	1 – 5 m H ₂ O

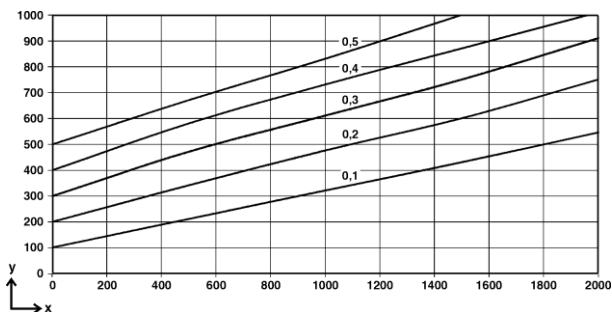

y Differenzdruck [mbar]

x Durchflussmenge [l/h]

42384

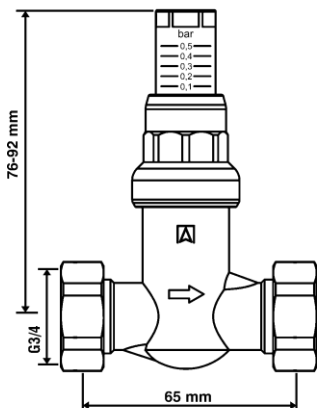

42379

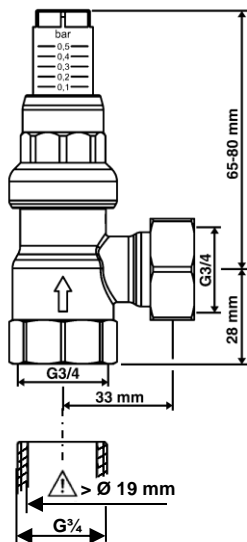

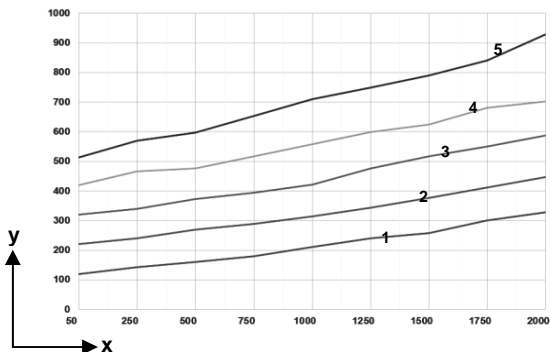

y Differenzdruck [mbar]

x Durchflussmenge [l/h]

42308

42460

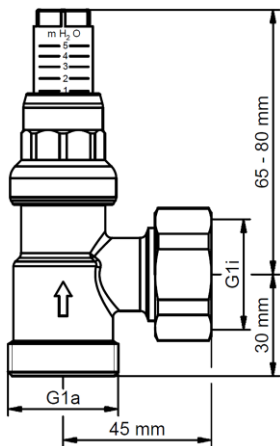
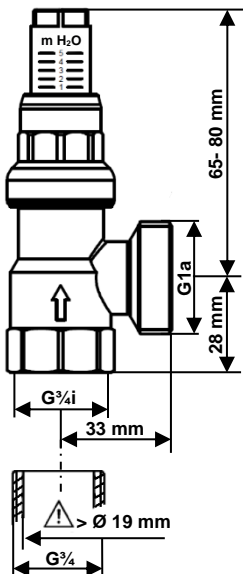

Mounting instructions

Differential bypass valve DÜ

Lindenstraße 20
74363 Güglingen

Telephone +49 7135 102-0

Service +49 7135 102-211

Telefax +49 7135 102-147

info@afriso.com

www.afriso.com

The differential bypass valve DÜ may only be installed in sealed heating systems as per EN 12828. It keeps the pump pressure at a constant level and helps to avoid flow noise during partial load operation. The differential bypass valve opens if the pumping pressure exceeds the value adjusted at the differential bypass valve.

- ▶ Install the differential bypass valve in a bypass line between the flow and the return.

Parameter	Value
Operating temperature	Max. 95 °C (short-term max. 120 °C)
Operating pressure	Max. 6 bar
Differential pressure	Fully adjustable
# 42379	0,1 – 0,5 bar
# 42384	0,1 – 0,5 bar
# 42308	1 – 5 m H ₂ O
# 42460	1 – 5 m H ₂ O

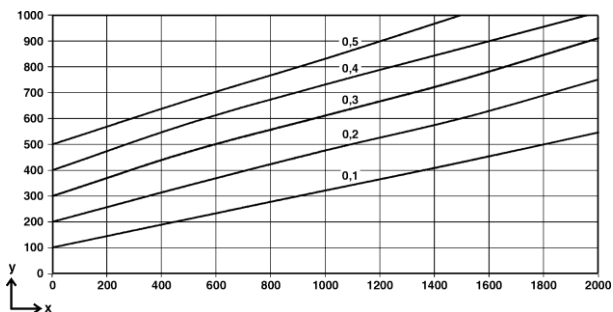

y differential pressure [mbar] x flow rate [l/h]

42384

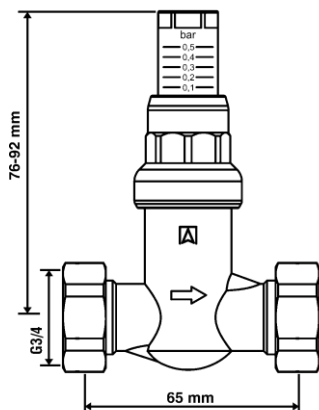

42379

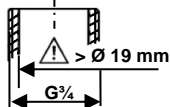
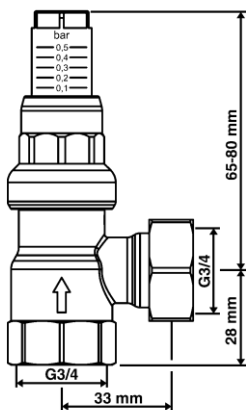

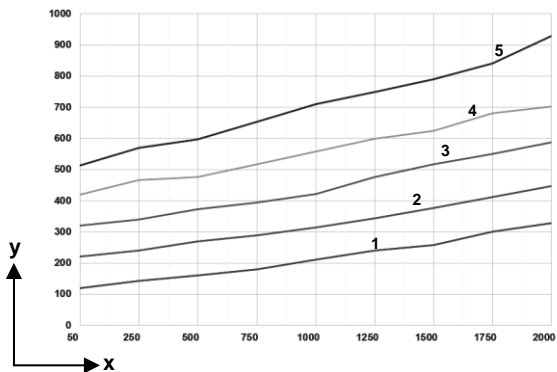

y differential pressure [mbar]

x flow rate [l/h]

42308

42460

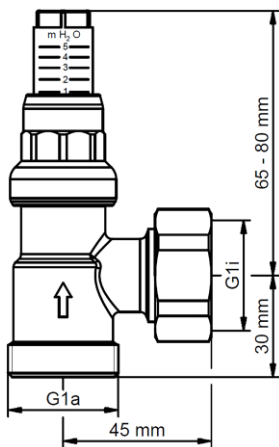
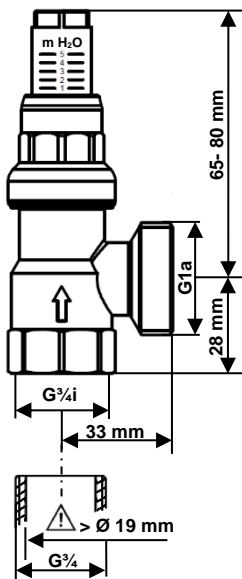

Instructions de montage

Limiteur de pression différentiel DÜ

Lindenstraße 20
74363 Güglingen

Téléphone +49 7135 102-0

Service clientèle +49 7135 102-211

Téléfax +49 7135 102-147

info@afriso.com

www.afriso.com

Le limiteur de pression différentiel est destiné exclusivement à l'installation dans les systèmes de chauffage fermés selon EN 12828. Il maintient la pression de la pompe constante et évite les bruits d'écoulement en fonctionnement à charge partielle. Le limiteur de pression différentiel s'ouvre lorsque la pression de la pompe dépasse la valeur réglée sur le limiteur de pression différentiel.

- Installez le limiteur de pression différentiel dans une ligne de bypass entre le départ et le retour.

Paramètre	Valeur
Température de service	Max. 95 °C (passagèrement jusqu'à 120 °C)
Pression de service	Max. 6 bar
Pression différentielle	Réglable en continue
# 42379	0,1 – 0,5 bar
# 42384	0,1 – 0,5 bar
# 42308	1 – 5 m H ₂ O
# 42460	1 – 5 m H ₂ O

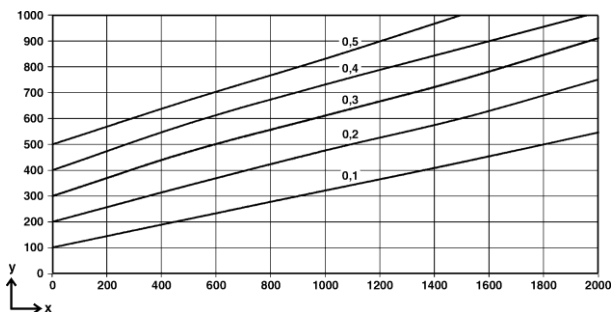

y pression différentielle [mbar]

x débit [l/h]

42384

42379

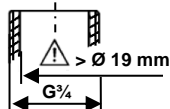
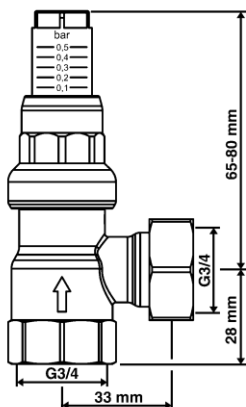
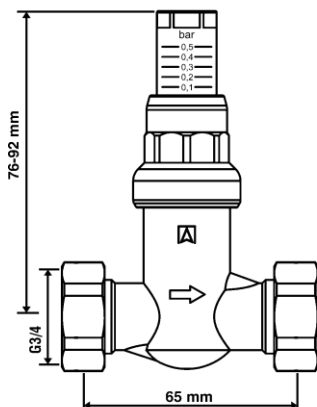

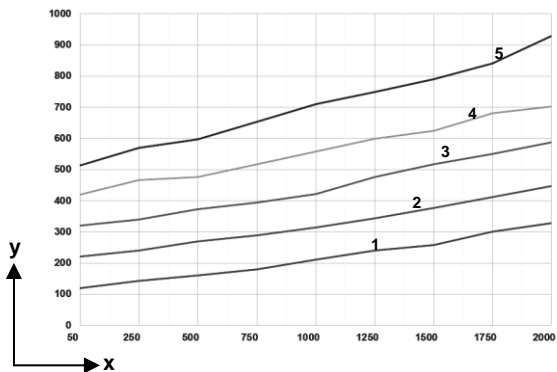

y pression différentielle [mbar] x débit [l/h]

42308

42460

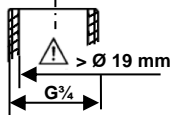
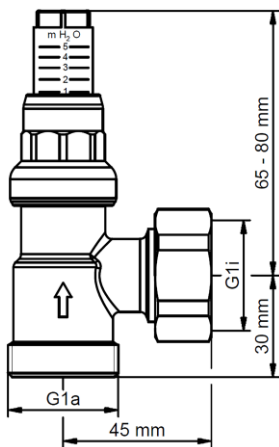
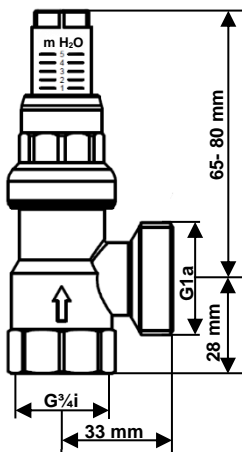

Instrukcja montażu

Różnicowy zawór przelewowy DÜ

Lindenstraße 20
74363 Güglingen

telefon +49 7135 102-0

serwis +49 7135 102-211

telefaks +49 7135 102-147

info@afriso.com

www.afriso.com

Różnicowy zawór przelewowy nadaje się wyłącznie do montażu w zamkniętych instalacjach grzewczych według normy EN 12828. Utrzymuje on ciśnienie pompy na stałym poziomie i zapobiega niepożądanym szumom przepływowym podczas pracy pod częściowym obciążeniem. Różnicowy zawór przelewowy otwiera się, gdy występujące ciśnienie pompy przekracza wartość ustawioną w różnicowym zaworze przelewowym.

- ▶ Różnicowy zawór przelewowy należy zamontować w przewodzie obejściowym pomiędzy zasilaniem i powrotem.

Parametr	Wartość
temperatura robocza	maksymalnie 95 °C (krótkookresowo maksymalnie do 120 °C)
ciśnienie robocze	maksymalnie 6 bar
ciśnienie różnicowe	płynna regulacja
# 42379	0,1 – 0,5 bar
# 42384	0,1 – 0,5 bar
# 42308	1 – 5 m H ₂ O
# 42460	1 – 5 m H ₂ O

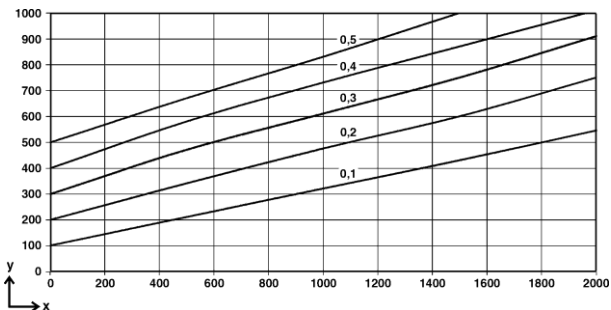

y ciśnienie różnicowe [mbar] **x** natężenie przepływu [l/h]

42384

42379

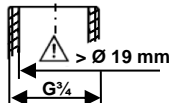
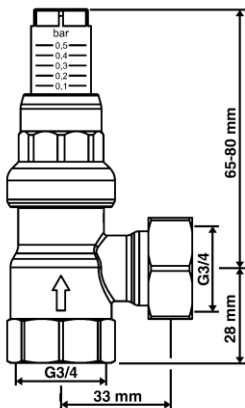
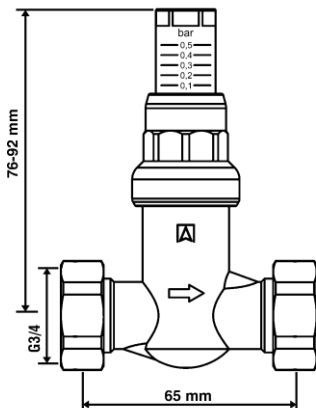

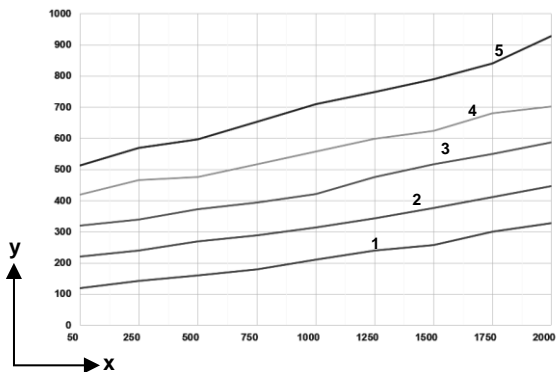

y ciśnienie różnicowe [mbar] x natężenie przepływu [l/h]

42308

42460

