



13 801 710



- Ausladung 200 mm
- runder Normalstrahl
- Bohrungsdurchmesser 37 mm
- Anschluss 1/2"
- Steckanschluss-Montage
- Durchfluss max. 23,5 l/min bei 3 bar Fließdruck

	Platin gebürstet	13 801 710-06
	Chrom	13 801 710-00

Empfohlenes Zubehör



- UP-Wandwinkel -** 35 085 970 90
- Max. Einbautiefe 163 mm
 - Min. Einbautiefe 90 mm

13 801 710

mm [Inches]

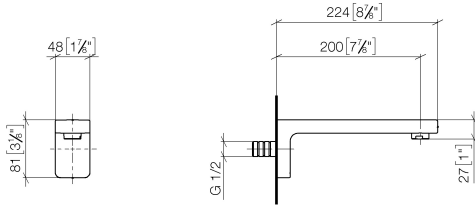

Durchflussdiagramm

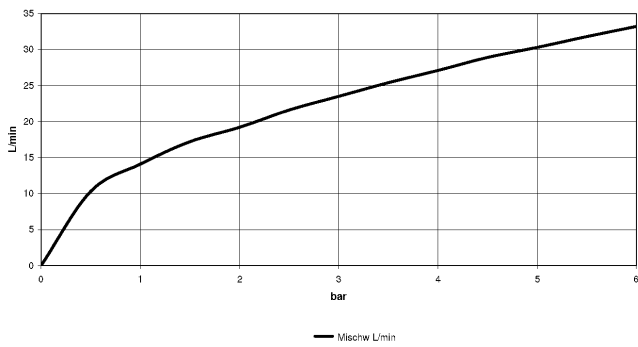

Codes & Standards

ASME A112.18.1

cUPC

DIN 4109

ISO 3822

Scottish Water
Byelaws

UK Water Supply
Regulations

Ü-Zeichen



LULU Wannenauslauf für Wandmontage - Platin gebürstet

LULU

13 801 710

Zertifikate

LGA_9

IAPMO_4976

WRAS_2305

Produktversion ab 3/31/2009

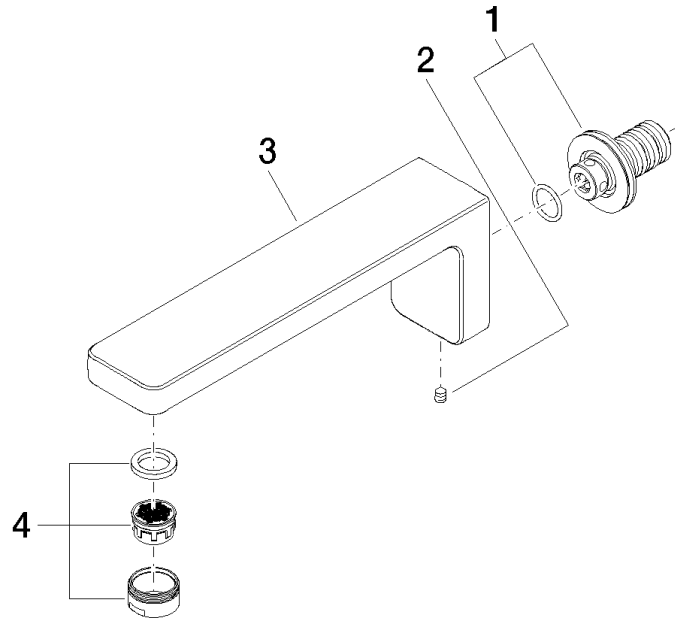



LULU Wannenauslauf für Wandmontage - Platin gebürstet

LULU

13 801 710

Ersatzteilstückliste

Produktversion ab 3/31/2009

Nr.	Artikelnummer	Benennung	Verbaumenge	Lieferzeit
	90 24 03 108 00 90	Nippel Ø 40 x 50 mm, 5 l/min. -	4	2